

GUIDANCE NOTE: PEEL ADHESION TESTING AND ASSESSMENT OF ANTI-SHATTER FILM (ASF)

CPNI EBP 10/13: December 2013

Disclaimer:

Reference to any specific commercial product, process or service by trade name, trademark, manufacturer, or otherwise, does not constitute or imply its endorsement, recommendation, or favouring by CPNI. The views and opinions of authors expressed within this document shall not be used for advertising or product endorsement purposes.

To the fullest extent permitted by law, CPNI accepts no liability for any loss or damage (whether direct, indirect or consequential and including, but not limited to, loss of profits or anticipated profits, loss of data, business or goodwill) incurred by any person and howsoever caused arising from or connected with any error or omission in this document or from any person acting, omitting to act or refraining from acting upon, or otherwise using, the information contained in this document or its references. You should make your own judgement as regards use of this document and seek independent professional advice on your particular circumstances.

Introduction

This guidance note replaces HOSDB 11B/08: Guidance Note: Assessment of Anti-Shatter Film (ASF) 11 June 2008 (Edition 1) and HOSDB 11C/08: Guidance Note: Peel Adhesion Testing of Anti-Shatter Film (ASF) 11 June 2008 (Edition 1). It has been issued in order to provide updated guidance on the peel adhesion testing and assessment of ASF, sometimes referred to as Fragment Retention Film (FRF).

Peel tests

Peel adhesion testing is a technique that can be used for checking the application of new ASF or testing the effectiveness of aged ASF, estimating the remaining serviceable life. It tests the adhesion of the film to the glass by applying a force to a narrow strip of ASF and measuring the weight needed to cause peeling and the rate of peel. The test does not provide a measure of the strength of the film.

Assessment of existing ASF







The facility manager should be asked to provide details of the ASF installation from the building's Health and Safety File. Although most currently available ASF carries a 10-15 year manufacturer's warranty if installed by an approved installer, there may be variability in the observed useful life due to cyclic temperature/weather extremes.

Known deficiencies of ASF over time include loss of strength and the onset of embrittlement within the base film due to ultra-violet degradation and loss of adhesion to the glass. These deficiencies are generally not visually apparent. Very old films may also only be 50 micron thick (.002") compared to current recommendations of at least 100 micron (.004") when BBNC are installed, and thicker or stronger film when BBNC are omitted. These thin films should be replaced.

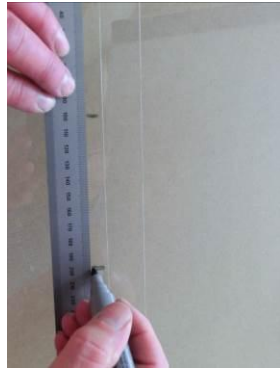
Other problems which might affect the useful life of the film can include bubbles, cloudiness, cuts/scratches/abrasions and de-lamination at the edges of the ASF.

Standard peel test

Table 1 - A step by step guide to conducting a peel test

<p>Step 1</p> <p>Cut two 25mm wide strips at least 400mm preferably 600mm long or the full height of the window. One of these should be in the centre of the window and one on the outer third but not closer than 75mm from the edge. (See figure 2)</p>		<p>Step 2</p> <p>Mark 100mm intervals down the side of the strip on the remaining film.</p>	
<p>Step 3</p> <p>Carefully peel back the strip to allow the weight to hang freely and to make the peel angle between 170° and 180° - up to 150mm of free film may be needed.</p>		<p>Step 4</p> <p>Attach the weight hanger by threading the strip of film through the clamping bars.</p>	
<p>Step 5</p> <p>Attach the 800g weight and ensure that it does not move under this condition. If the weight moves at this stage, the adhesive has either not cured sufficiently or is not strong enough and a fail should be recorded.</p>		<p>Step 6</p> <p>Add the 700g weight to give 1500g total. Pull the strip gently down to one of the 100mm marks and hold the weights in this position. The stop watch should be zeroed.</p>	
<p>Step 7</p> <p>Start the stop watch at the same time as gently releasing the weights.</p>		<p>Step 8</p> <p>Record the time intervals for each of the 100mm drops. The time for each 100mm length should normally be less than 20 seconds. However, it is normal for the peel rate to start faster and gradually slow down. The total time for 300mm must not be less than 1 minute.</p>	

Equipment

The following equipment is required to conduct a peel test:

- Set of peel adhesion test weights - 200g, 250g, 700g, 800g including Hanger (50g) (see Figure 1).
- Sharp knife
- Steel ruler
- Marker pen
- Stop watch

Conducting a peel test

- Carry out peel test as demonstrated in Table 1.
- Record all details of weights, times, film, date of test, general weather conditions and location by window, room and building elevation and pass or fail in an agreed tabular format.
- To ensure that the adhesive is not too brittle it is necessary to conduct an additional test using a larger weight. In this test the adhesive is required to move, and not break, under a weight of 4000g. The standard peel adhesion test kit contains weights for 2000g. To conduct the adhesive test a second test kit is required or by agreement a pull spring balance may be used to augment the accepted weights apparatus, provided failures are not being encountered. Where a borderline case is identified using a pull spring balance it should be retested using weights.
- Tensile strength, ultra-violet inhibition capacity, wetting solution used, glass tint and properties of adhesives, solar control and laminated films are other factors that may require consideration and alter the results of the peel test.
- If film embrittlement is so severe that the ASF repeatedly breaks upon application of the weights or spring balance force, then a peel test failure shall be recorded.



Figure 1 – Peel adhesion test kit

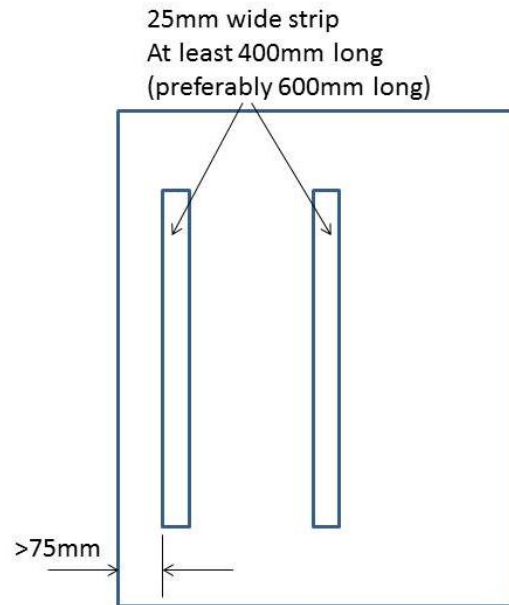

Figure 2 – Location of peel adhesion test, test strips

When to conduct peel tests for newly installed ASF

Peel tests should be conducted 28-90 days after installation or when it is necessary to ascertain the effectiveness of the ASF or gain an indication of how much longer the film may be used. For newly installed ASF, as a guide only, tests should be carried out at the following intervals after installation:

- 28 days for 100 micron film
- 42 days for 175 micron film
- 90 days for 300 micron film

It should be noted that tinted glass, window elevation and inside/outside temperature will all have an impact on the ability of the wetting solution to evaporate and therefore the length of time before a film can satisfactorily hold weight may be longer than that quoted above.

The dynamic peel adhesion test requirements for new ASF are:

‘A 25 mm wide peeled strip shall hold 800g with negligible movement and carry 1,500g stripping at no faster than 300mm per minute’.

In general one peel test should be performed for every 50m² to 300m² of installed ASF, depending on the size of the building.

Effectiveness testing for existing ASF

Where an assessment of the effectiveness of a film to provide mitigation against a specific level of risk from explosion is required, it is recommended that the following weights should be applied to test whether the existing ASF remains effective. Failure at these weights means that immediate replacement of the ASF is required if effective mitigation is to be maintained.

Risk from explosion	Standard
High/moderate risk	Hold a minimum of 500g
Low risk	Hold a minimum of 250g
Insignificant risk	Hold < 250g but > 100g

Table 2 – Recommended weights for testing the effectiveness of ASF

The above 'static' weights should 'hold' with negligible movement of a 25mm wide strip. The weights are for guidance only, and may need some adjustment depending on the building risk, ASF age, ASF thickness and the degree of embrittlement. If film embrittlement is so severe that the ASF repeatedly breaks upon application of the weights or spring balance force, then a peel test failure shall be recorded.

Lifetime testing

Where an assessment of the remaining useful life of an ASF is required, the lifetimes shown in Table 3 are indicative of the minimum expected remaining lifetime for the ASF rather than a guarantee. This is because environmental conditions vary considerably, thereby affecting lifetime.

Re-testing of different panes upon expiry of the expected minimum useful life is recommended. The Glass and Glazing Federation (GGF) recommend that the following test weights are used:

Risk from explosion	Weights to use for a minimum remaining useful life of:		
	2 years	4 years	6 years
High risk	700g	950g	1,300g
Low risk	500g	700g	-

Table 3 – Recommended weights for testing the remaining useful life of ASF